



APOLO

Pumps | Pumping Systems

PROCESS PUMPS AND SYSTEMS

GENERAL CATALOG

CUSTOMER - SPECIFIC SOLUTIONS

INNOVATION | QUALITY | MADE IN GERMANY

Apollo is one of the most experienced manufacturers of individual, reliable and high-quality pumps, system equipment and various systems in process engineering. We offer technically the best possible solutions to our international customers from the refineries, offshore, power plant and oil & gas industries. Due to our comprehensive product range, from product development to the production of system plants and process pumps, we can provide our customers with full support already in their planning phases.

1863



established as machine factory and foundry



specializing in development and manufacture of pumps and compressors

1963

100th anniversary

1920

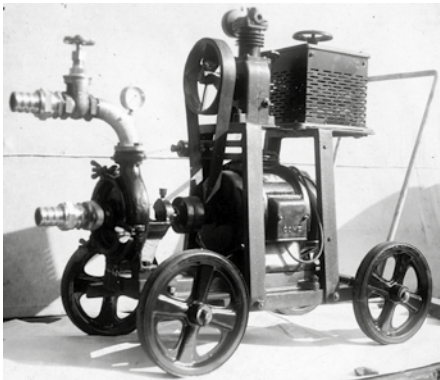

1950

The product range was specialized for power plant engineering, chemistry and process technology as well as for special cases.



**«SINCE OVER 100 YEARS
APOLLO IS DESIGNING AND
MANUFACTURING PUMPS»**

With the expertise gathered over many decades, we have specialized in the development and production of customer-specific pumps and pumping systems according to international industry standards as well as API. Based on synergies between pump manufacture and in-house production of system technologies as well as engineering plants, complete solutions can be provided from Apollo as a single source.



Headquarter office in Gößnitz

2013

Apollo was celebrating its 150th anniversary



intensive company expansion in all areas of the company

2018

System Engineering Division was established

1990

Apollo is a worldwide acting company and manufactures top-quality process pumps and plant fluid systems.

2024

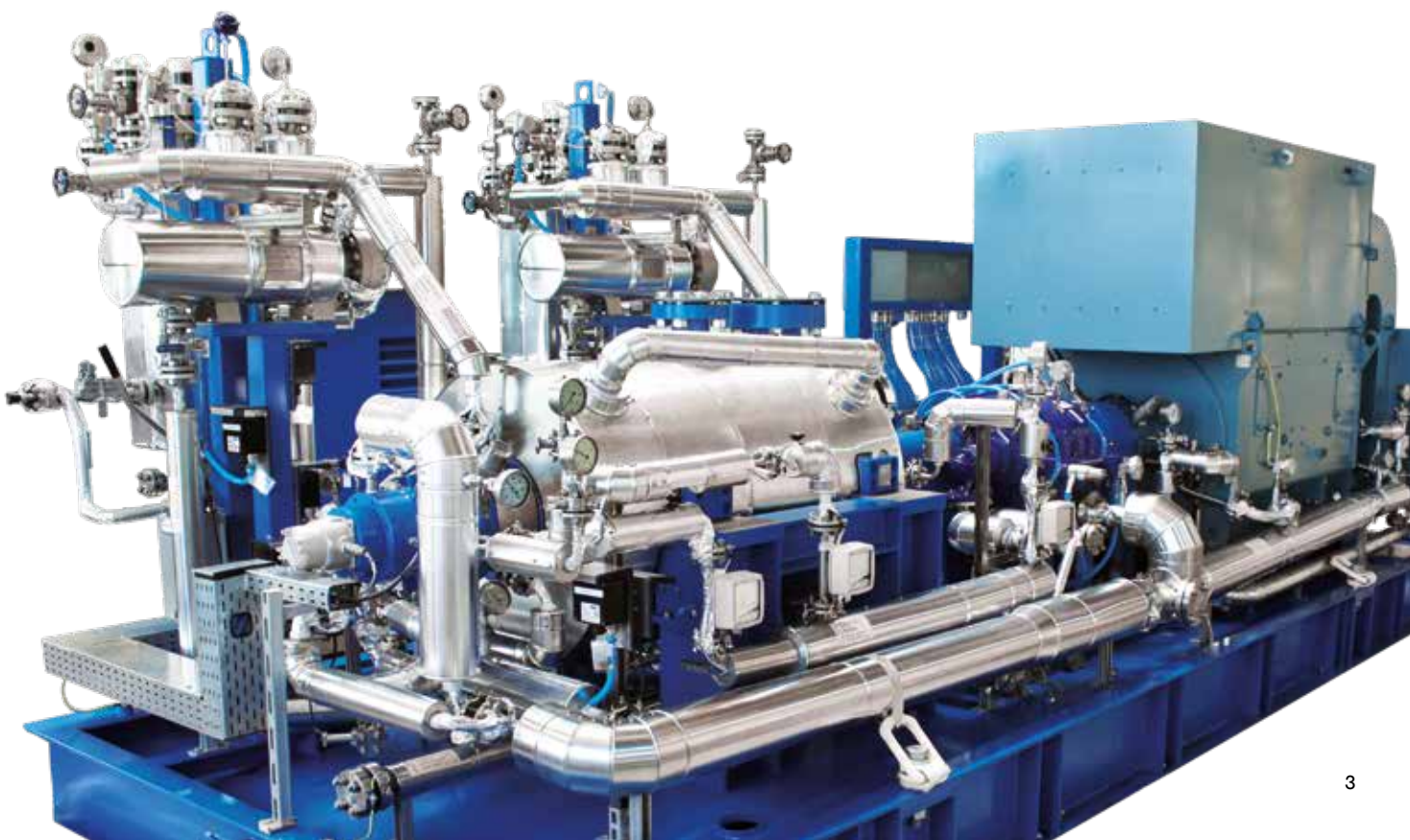



TESTING

All of our products can be tested according to the current valid norms and standards at our testing facilities up to 10 000 m³/h capacity range and 4 200 m pressure head, as well as drive powers up to 4,4 MW and voltage levels between 400 V and 13 KV. It is also possible to use a frequency converter for speed control of pump units on the test field. Complete unit test under real conditions.

MATERIAL

Based on special customer requirements, the specific fluid to be pumped and other conditions, a wide range of suitable material solutions are available.

- Cast Iron / Cast Steel
- Stainless Steel / Austenitic Steel
- Duplex and Super Duplex
- Titanium, Inconel and special alloys according to Norsok or NACE

FABRICATION

Short distances and permanent expansion of in-house production optimization ensure a smooth process from planning to the manufacture of pumps, pump units and systems.

Modern multifunctional machines with a high degree of automation, multi-machine operation, our own sandblasting and painting facilities, pump and system assembly as well as welding and electrical engineering departments guarantee efficient cooperation between all company divisions, fast processing times and high manufacturing flexibility.

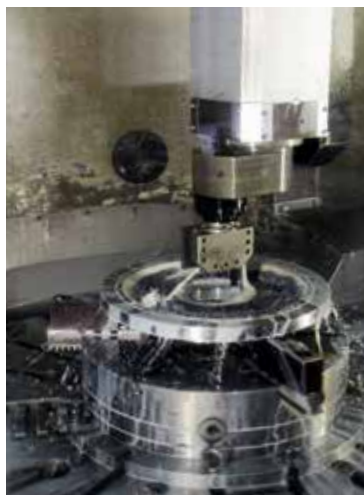

INNOVATION AND ENGINEERING EXPERTISE

ENGINEERING

The competent design and development team has many years of experience and is fully aware of all the individual customer requirements in different industries.

We provide the full range of up-to-date development methods of design, like continuous hydraulic design using CFD software. Finite element analysis for components as well as simulations for complete units, lateral-torsional analysis and 3D-CAD/CAM interface for fabrication of casting patterns and pump components can be provided.

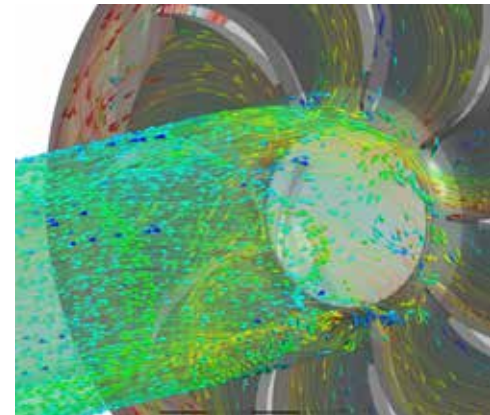
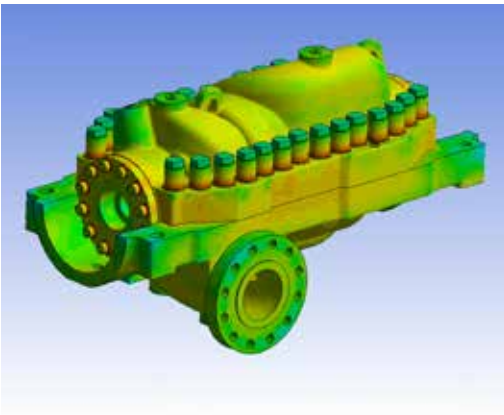

QUALITY

The central tasks include comprehensive quality tests and analyses for the quality assurance of all manufactured products with complete manufacturing documentation (material and component tests - mechanical, metallurgical as well as lifetime control, and failure analyses). The pumps and systems are designed, manufactured and tested in compliance with standards such as API, DIN EN ISO or ASME. Apollo's quality management system meets the requirements of the ISO 9001 standard.

«DESIGN AND MANUFACTURING AS AN IN-HOUSE SERVICE»



THE RIGHT PUMP SOLUTION FOR ANY REQUIREMENT

For many years, Apollo pump and system equipment has been an integral part of numerous sectors, such as the oil and gas industry, the chemical industry, the water and fertilizer industry, power generation or even the handling of renewable energies.

The reliability and efficiency of our products enables a wide variety of applications around the globe to operate more efficient and resource-saving.

ENERGY INDUSTRY



Apollo - partner for energy-efficient pump solutions. Maximize efficiency and performance with Apollo's cutting-edge technology for a more sustainable and environmentally-friendly operation.

OIL AND GAS INDUSTRY



Apollo is a reliable supplier of top-quality pumps for the global oil and gas industry. Apollo provides high-quality pumps and equipment for global processes, supported by an experienced team.

CHEMICAL INDUSTRY

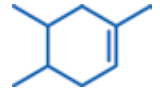

The Apollo product portfolio easily handles high complexity and equipment requirements, even in chemical industry processes.

OFFSHORE / ONSHORE



Apollo designs and manufactures individual solutions for almost any application - according to your needs. Whether for platforms, FPSO's, FSO's or downstream processing plants.

WATER INDUSTRY



Apollo provides a diverse selection of water pumps and systems to fit any need, whether it's for water treatment, transportation or distribution.

FERTILIZER INDUSTRY



Apollo has decades of experience in the fertilizer industry and can provide service to almost any process with a wide range of special materials.

RENEWABLE ENERGY



Apollo pumps and systems provide efficient and economical power to hydropower, geothermal, and waste-to-energy plants worldwide.

GENERAL INDUSTRY



The Apollo product portfolio offers a wide range of applications for various industrial sectors, such as booster sets, desalination plants, water distribution and supply, process water, and chemical solution circulation.

SULPHATE REMOVAL FEED PUMP acc. to API 610 | BB2 at oil platform in the North Sea

- APOLLO pump type: **ZPR-150/500-618/CN**
- Pump power: 694 kW (555 m³/h of 341 m)
- Material: super duplex acc. to NORSOK



API 610 HIGH QUALITY PROCESS PUMPS

OH1

Foot-mounted, single-stage overhung pumps



OH2

Centerline-mounted, single-stage overhung pumps



OH3

Vertical, in-line, single-stage overhung pumps

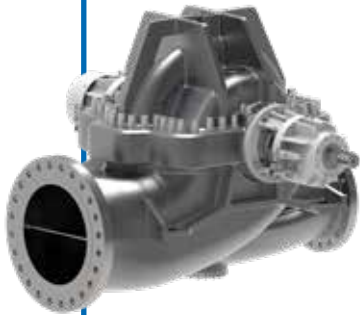

BB1

Axially split, single-stage, between-bearings pumps



BB2

Radially split, one- and two-stage, between-bearings pumps

BB3

Axially split, multistage, between-bearings pumps



Apollo is specialized in the development and manufacturing of complex pumps and pumping systems suitable for a wide range of industries and applications. We offer the complete process chain, from engineering and mechanical processing to assembly, piping, electrical and PLC engineering. Our team can handle customer-specific requirements.

VS1

Wet pit, vertically suspended, single-casing diffuser pumps



VS4

Vertically suspended, single-casing, volute, line-shaft-driven sump pumps

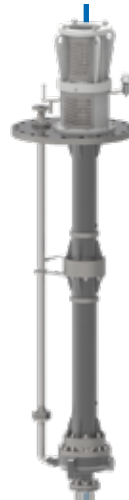

VS6

Double-casing, diffuser, vertically suspended pumps



BB4

Single-casing, radially split, multistage, between-bearings pumps

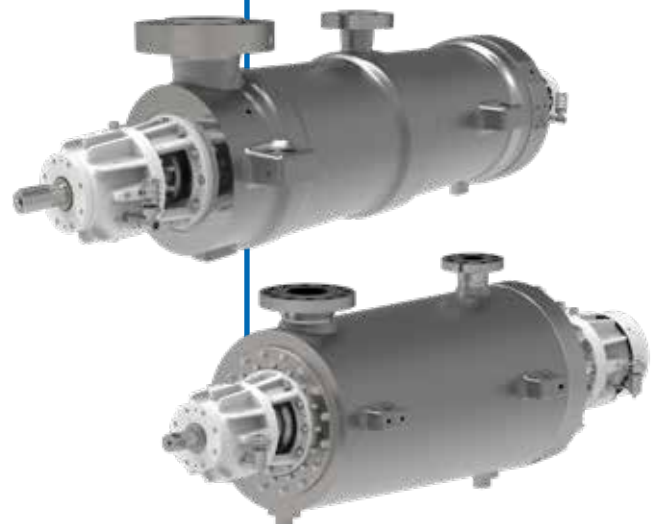
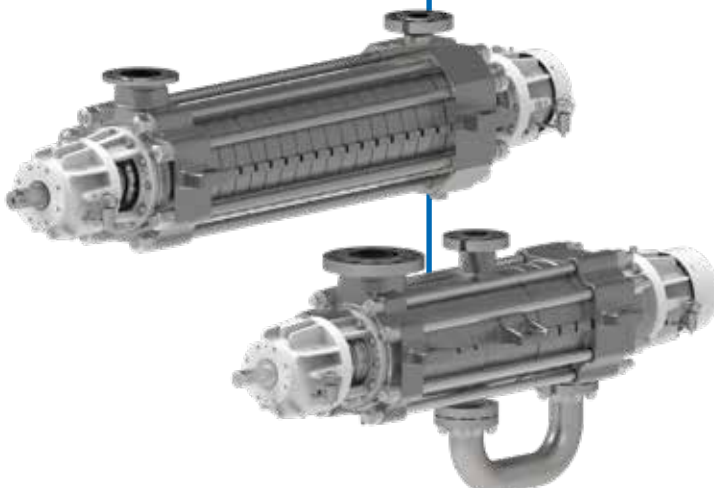

BB5

Double-casing, radially split, multistage, between-bearings pumps



OH1 Pumps

Type KRC / KRP

Horizontal, single-stage, radially split, heavy-duty foot-mounted pumps

Design features

- axial suction nozzle, radial discharge nozzle
- foot-mounted
- reduction of axial forces
- low vibration – long service life
- back-pull-out version
- seal area acc. to API 610/682, suitable for a variety of seals
- exchangeable wear rings enable easy maintenance and cost reduction

KRP

Q (m ³ /h)	2 800
H (m)	250
P (bar)	25 / 35
T (°C)	+150





OH2 Pumps

Type KRH / KRHA

Horizontal, single-stage, radially split, heavy-duty overhung pumps

Design features

- pump meets all requirements of API 610
- axial suction nozzle, radial discharge nozzle
- centre-supported
- back-pull-out version
- seal area acc. to API 610/682, suitable for a variety of seals
- design with inducer possible

	KRH	KRHA
Q (m ³ /h)	1 000	5 000
H (m)	320	220
P (bar)	55 / 90	55
T (°C)	+450	+450



KRH with Inducer



KRHA Version



OH2 Pumps

Type KRHL / KRPO / KGHL

Horizontal, single-stage/two-stage process pumps with semi-open impeller

Design features

- pump meets all requirements of API 610
- version for low capacity and high head
- single-stage, low-flow,
- two-stage KGHL version
- semi-open impeller
- optionally: exchangeable wear plate and inducer

	KRHL	KRPO	KGHL
Q (m ³ /h)	45	25	45
H (m)	270	210	350
P (bar)	50	50	50
T (°C)	+450	+450	+450

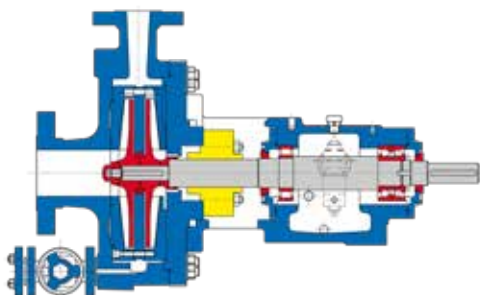

KGHL Version



RELIEF K.O. DRUM PUMP acc. to API 610 | OH2 at renewable process refinery complex

- APOLLO pump type: **KRH-40C/350-308/CN**
- Liquid: 200 °C Slop Oil
- with cooling equipment connected to the seal supply system and pump

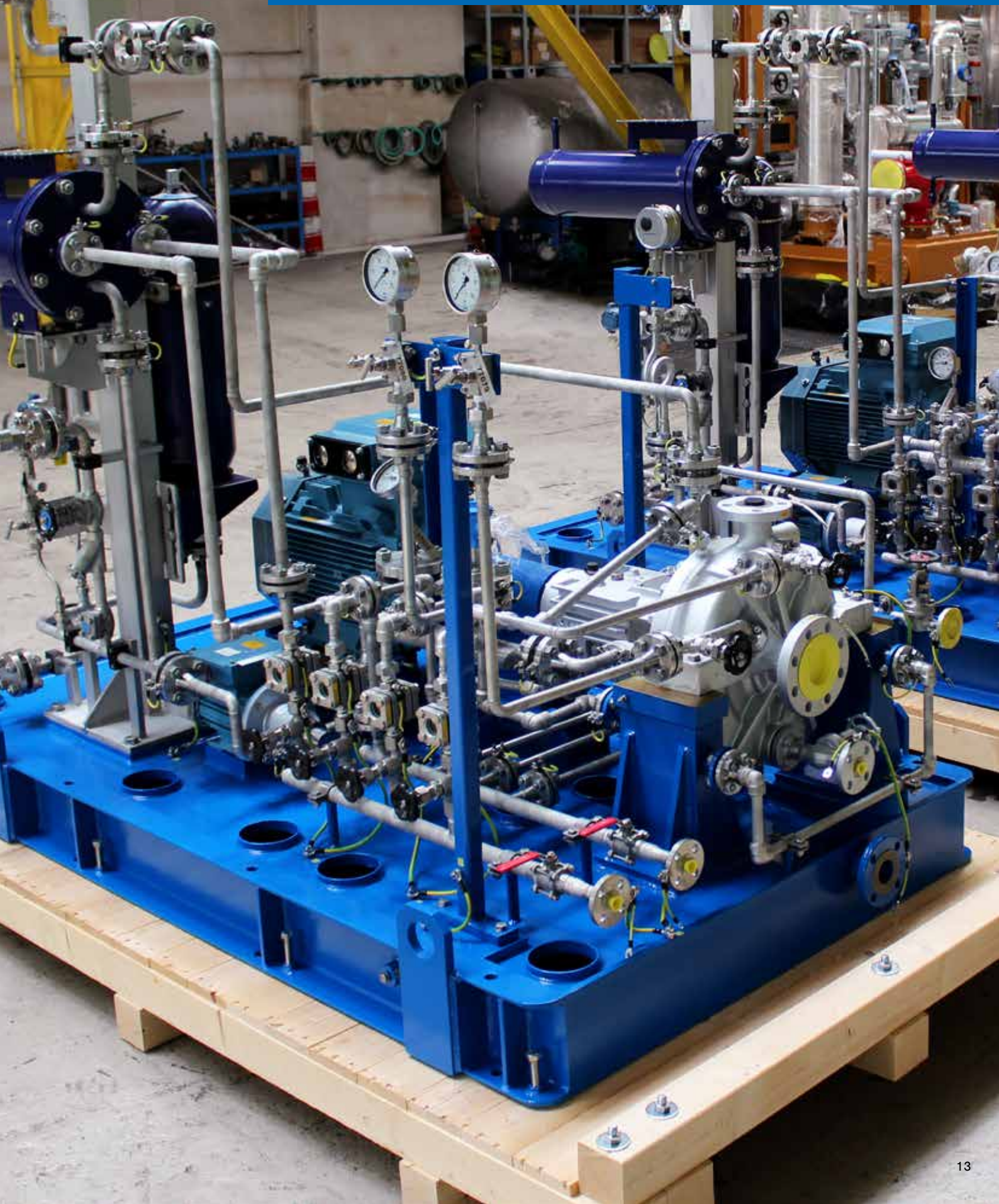

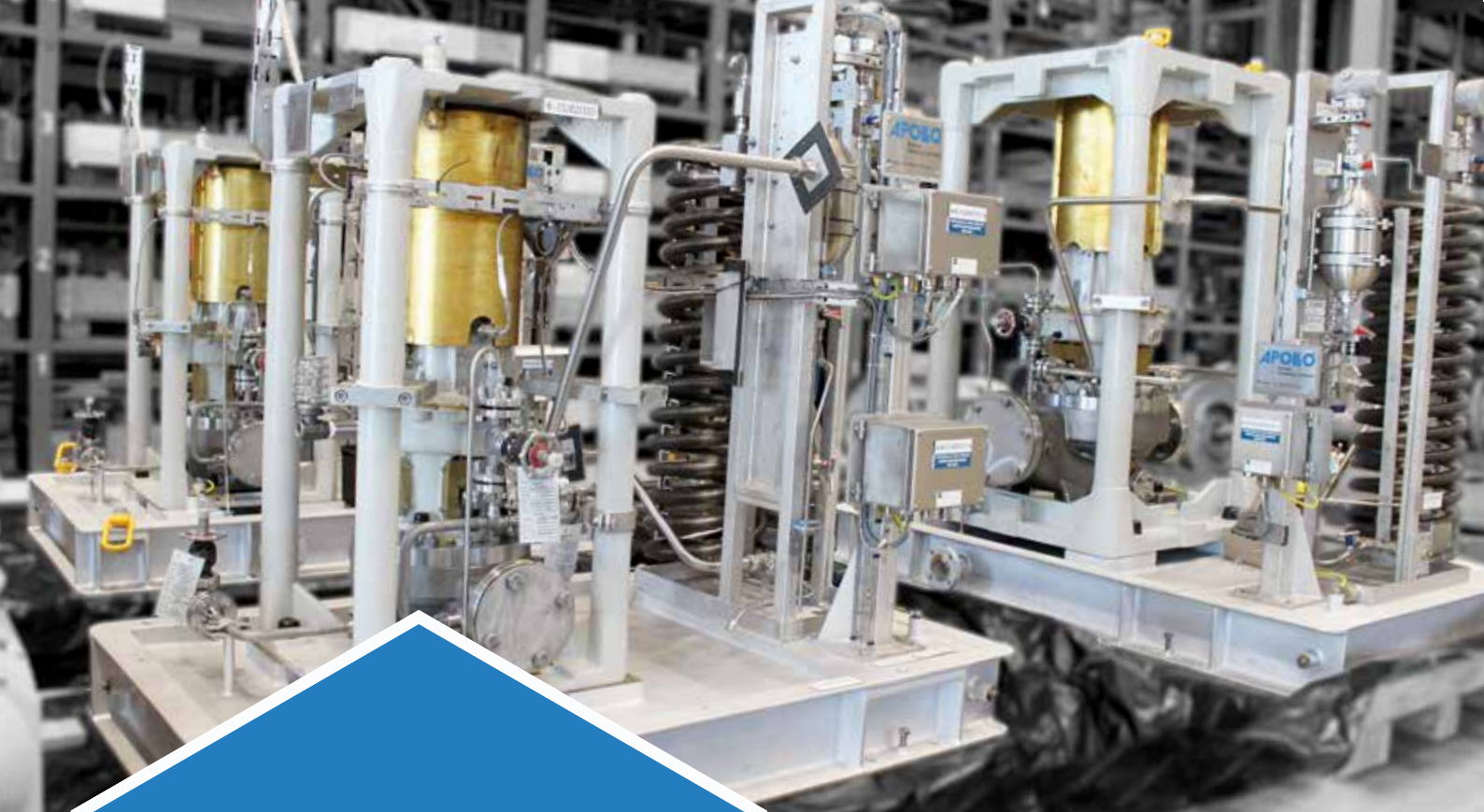

OH3 Pumps

Type KRI / KRIL

Vertical, single-stage, radially split process pumps as inline version

Design features

- pump meets all requirements of API 610
- vertical, single-stage pump of process design
- for installation with narrow footprint
- inducer version available
- discharge and suction nozzle are of inline arrangement
- KRIL as version for low capacity
- with grease or oil lubrication

	KRI	KRIL
Q (m ³ /h)	800	45
H (m)	270	270
P (bar)	55	50
T (°C)	+250	+250





BB1 Pumps

Type ZMK / ZMKV

Heavy-duty, axially split, single-stage process pumps, between-bearings version

Design features

- pump meets all requirements of API 610
- thrust compensation by double suction impeller design
- double-volute design
- replaceable wear rings ensure maximum maintainability and high operating safety
- ZMKV as vertical version
- bearing design: antifriction-, mixed- or slide bearings

	ZMK	ZMKV
Q (m ³ /h)	10 000	5 500
H (m)	140	140
P (bar)	25 / 40	25 / 40
T (°C)	+150	+150





BB2 Pumps

Type ZPR / ZPRA / ZPRV

Horizontal, single-stage, double suction process pumps, between-bearings version

Design features

- pump meets all requirements of API 610
- horizontal, single-stage, radial-split, heavy-duty design
- radial discharge nozzle
- centre-supported
- back-pull-out version
- design with inducer available
- ZPRV as vertical version

	ZPR	ZPRA
Q (m ³ /h)	1 500	4 000
H (m)	450	300
P (bar)	160	55
T (°C)	+450	+ 450



ZPRV Version



SRP FEED PUMP acc. to API 610 | BB2 at oil platform in the North Sea

- APOLLO pump type: **ZPRV-150/500-618/CN**
- special design as vertical BB2 pump
- Pump power: 448 kW (445 m³/h of 279 m)





BB2 Pumps

Type KGR / KGRD / KGRZ

Heavy-duty, radially split, two-stage process pumps between-bearings version

Design features

- axial thrust compensation due to back-to-back arrangement of impellers
- radially split casing and centre supported
- first impeller as single-flow or double-flow version
- bearing design: antifriction-, mixed- or slide bearings
- KGRZ as a special design for liquids with heavy solid content

KGR / KGRD

Q (m ³ /h)	1 600
H (m)	600
P (bar)	80
T (°C)	+450



KGRZ Version





BB3 Pumps

Type AMG

Horizontal, multistage, axially split high-pressure pumps between-bearings version

Design features

- pump meets all requirements of API 610
- axially split casing
- axial thrust compensation due to back-to-back arrangement of impellers
- special NPSH impeller in first stage
- bearing design: antifriction-, mixed- or slide bearings

AMG

Q (m ³ /h)	3 200
H (m)	2 200
P (bar)	265
T (°C)	+200

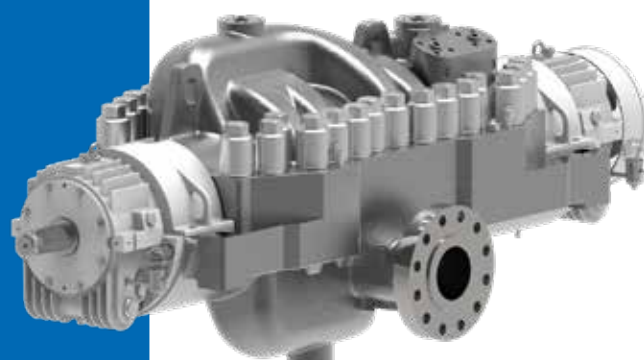



BB4 Pumps

Type HP

Horizontal, multistage high-pressure pumps of ring-section design

Design features

- designed with intermediate take-off and optimized pressure design within the pump
- special NPSH impeller available
- intermediate take off as option
- axial thrust compensation via balance piston, double piston or balance disk
- low vibration values
- bearing design: antifriction-, mixed- or slide bearings

HP

Q (m ³ /h)	1 800
H (m)	2 800
P (bar)	300
T (°C)	+250

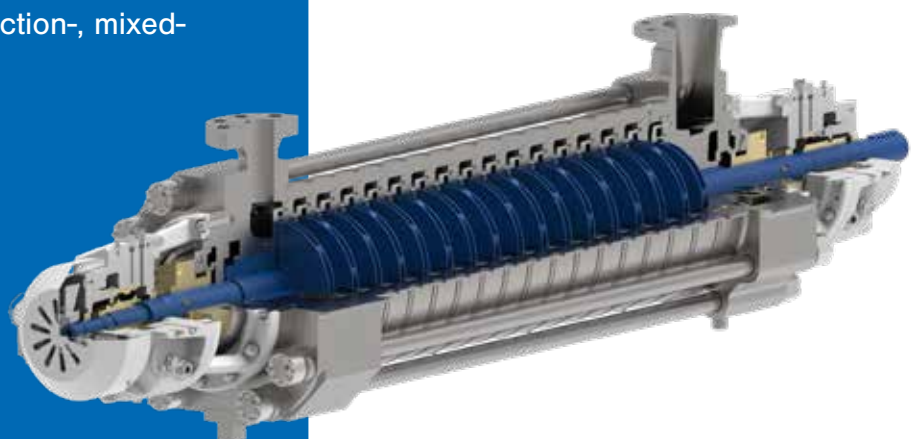



**BOILER FEED WATER PUMP acc. to API 610 | BB4
at ammonia plant**

- APOLLO pump type: **HPC-80D/12-508/CN**
- with Apollo ACS lube oil system acc. to API 614 on a separate base frame
- Pump power: 600 kW (123 m³/h of 1388 m)



BB4 Pumps

Type GP

Horizontal, multistage high-pressure pumps of back-to-back design

Design features

- multistage radial-split high pressure pump
- first stage designed as NPSH impeller
- centre-line supported
- bearing design: antifriction-, mixed- or slide bearings

GP

Q (m ³ /h)	600
H (m)	2500
P (bar)	250
T (°C)	+250



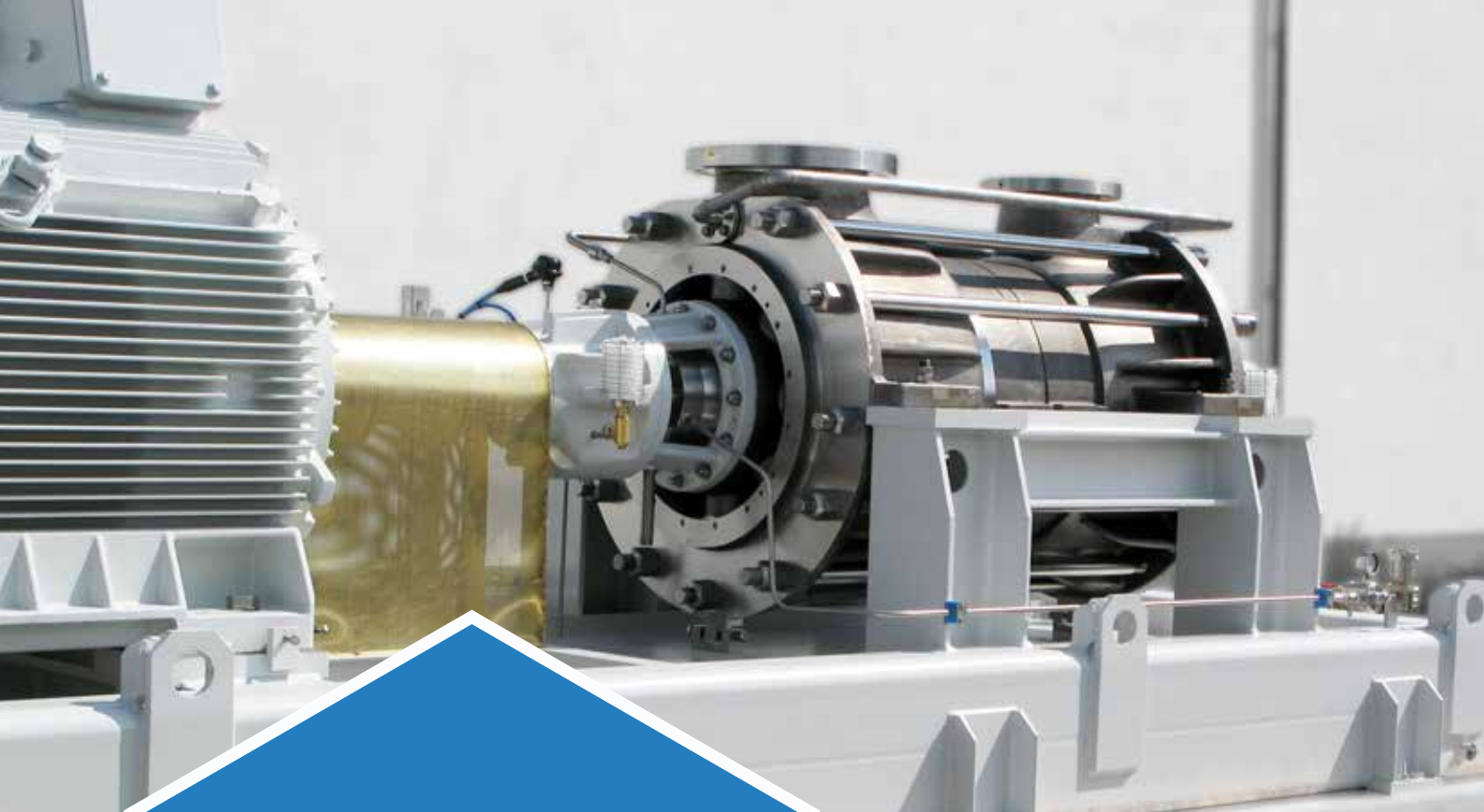

BB4 Pumps Type GMHD

Horizontal, multistage, high-pressure pumps with double-flow NPSH impeller

Design features

- first stage designed as double suction NPSH impeller
- axial thrust compensation by means of balance piston
- centre-line supported
- low vibration values
- bearing design: antifriction-, mixed- or slide bearings

GMHD

Q (m ³ /h)	1 100
H (m)	320
P (bar)	63
T (°C)	+180



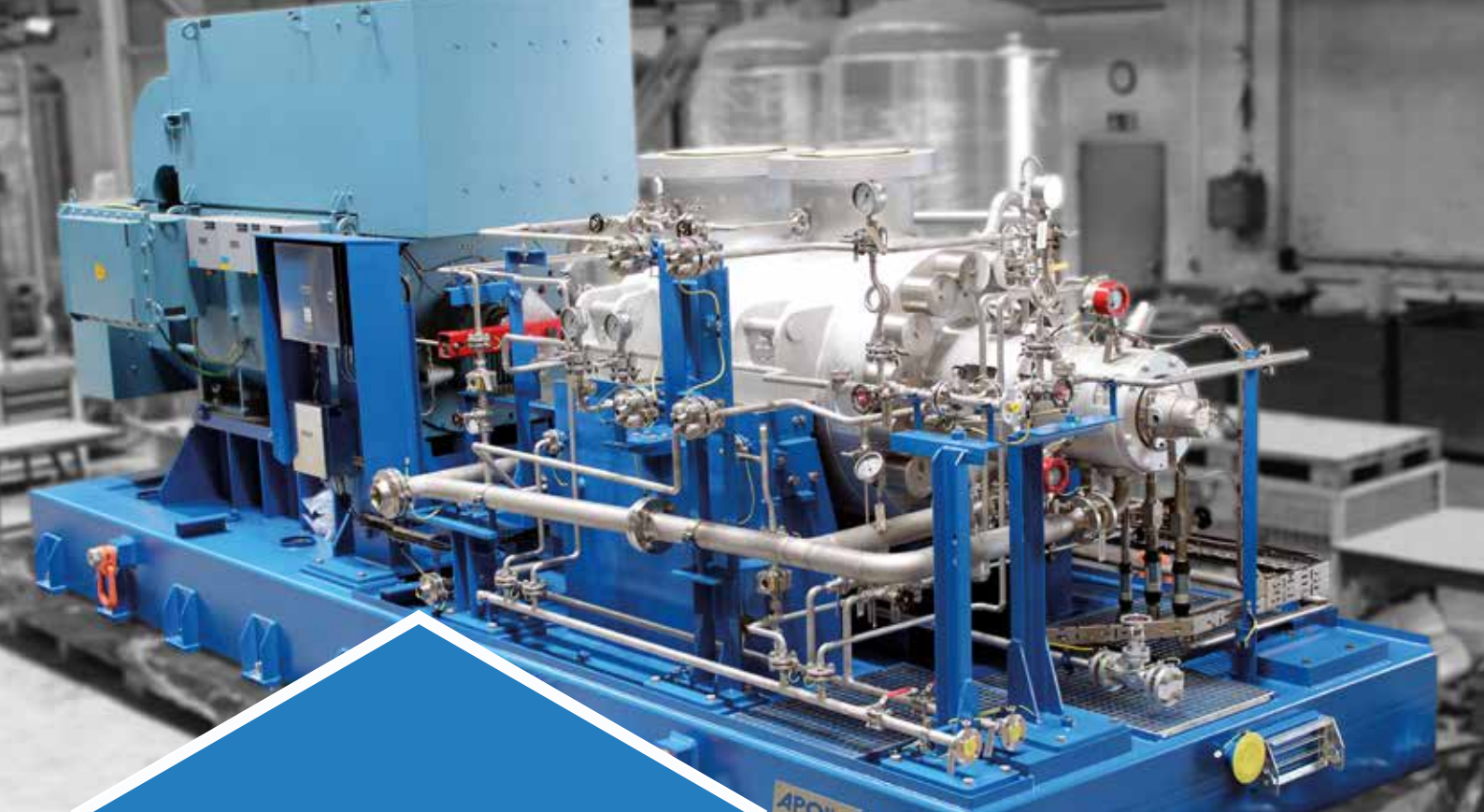

BB5 Pumps

Type TL

Horizontal, multistage high-pressure pumps of barrel design with inline rotor

Design features

- pump meets all requirements of API 610
- construction in pull-out version of a complete cartridge
- inline arrangement of impellers
- axial thrust compensation via balance piston, double piston or as an option as balance disk
- first stage designed with NPSH impeller
- centre-supported
- bearing design: antifriction-, mixed- or slide bearings

TL

Q (m ³ /h)	1 800
H (m)	2 800
P (bar)	350
T (°C)	+400

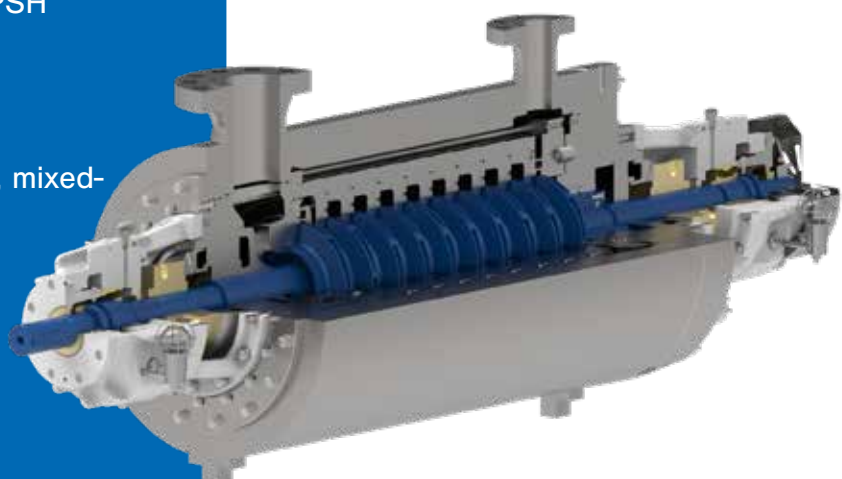
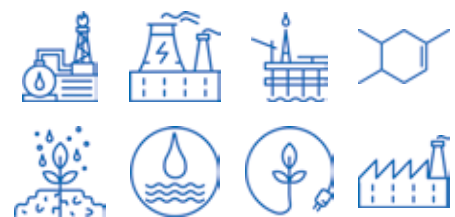



BB5 Pumps Type TG

Horizontal, multistage high-pressure pumps of barrel design with back-to-back rotor

Design features

- pump meets all requirements of API 610
- construction in pull-out version of a complete cartridge
- back-to-back arrangement of impellers, provides the smallest axial forces and very smooth running
- first stage designed as NPSH impeller
- centerline supported
- bearing design: antifriction-, mixed- or slide bearings

TG

Q (m ³ /h)	1 800
H (m)	4 200
P (bar)	450
T (°C)	+420

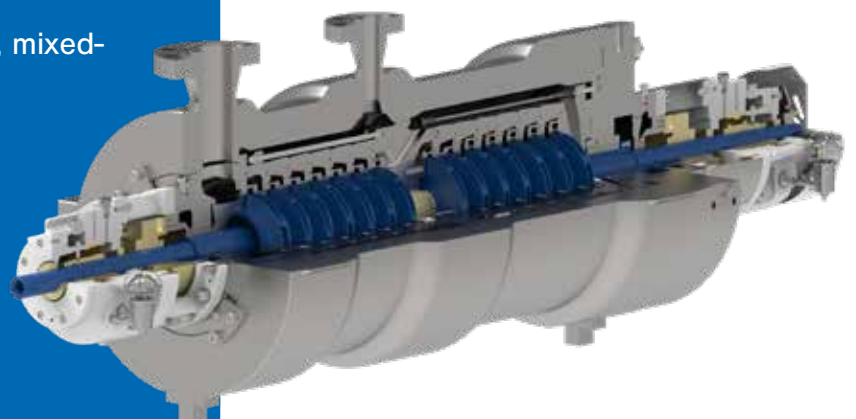

HGO / HVGO FEED PUMP acc. to API 610 | BB5 at renewable process refinery complex

- APOLLO pump type: **TGD-80D/8-399/CN**
- Including cooling equipment to seal supply system, electrical heat tracing, lube oil system (Apollo ACS), Plan 53A system and gear box
- Pump power: 1121 kW (168 m³/h of 2047 m)

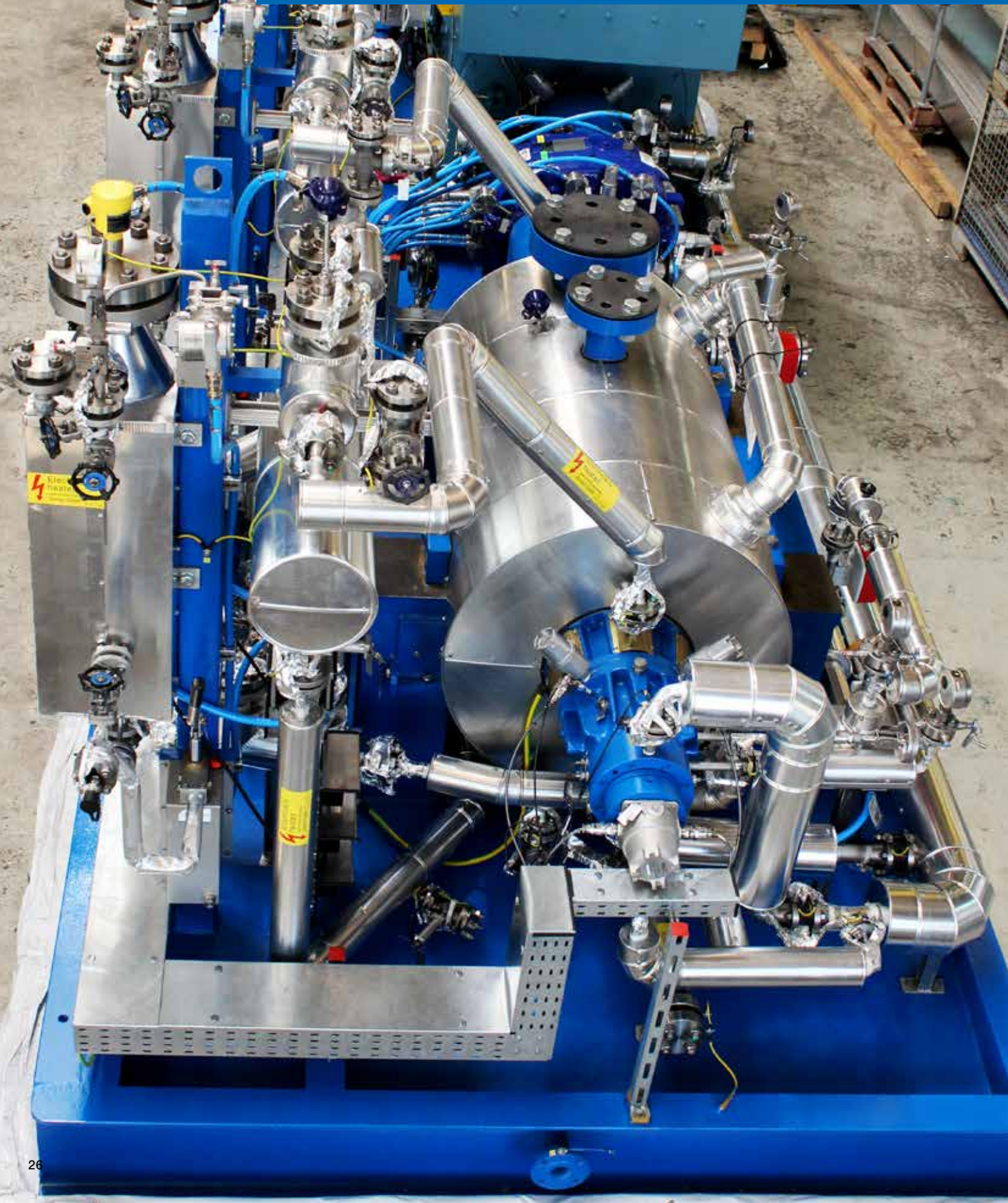



VS1 Pumps

Type HPV / HPVX

Vertical, multistage high-pressure pump as submerged pumps

Design features

- radial centrifugal pump with suspended NPSH impeller, depending on design length
- axial thrust compensation by means of balance piston
- liquid lubricated slide bearings in the pump
- bearing design: antifriction bearing or combination of axial-radial slide bearings
- as cryogenic version available

HPV

Q (m ³ /h)	600
H (m)	600
P (bar)	63
T (°C)	-140 / +180





VS4 Pumps

Type KRHV / KRCV

Vertical, single-stage, radially split, heavy-duty process pumps

Design features

- vertical volute-casing pumps for wet or dry installation with most different submersion depth up to 8 m
- shaft on drive with robust bearings of long life
- slide-bearing locations are lubricated by means of liquid to be pumped via lubrication piping
- bearings with oil or grease lubrication

KRHV

Q (m ³ /h)	500
H (m)	280
P (bar)	50
T (°C)	+250



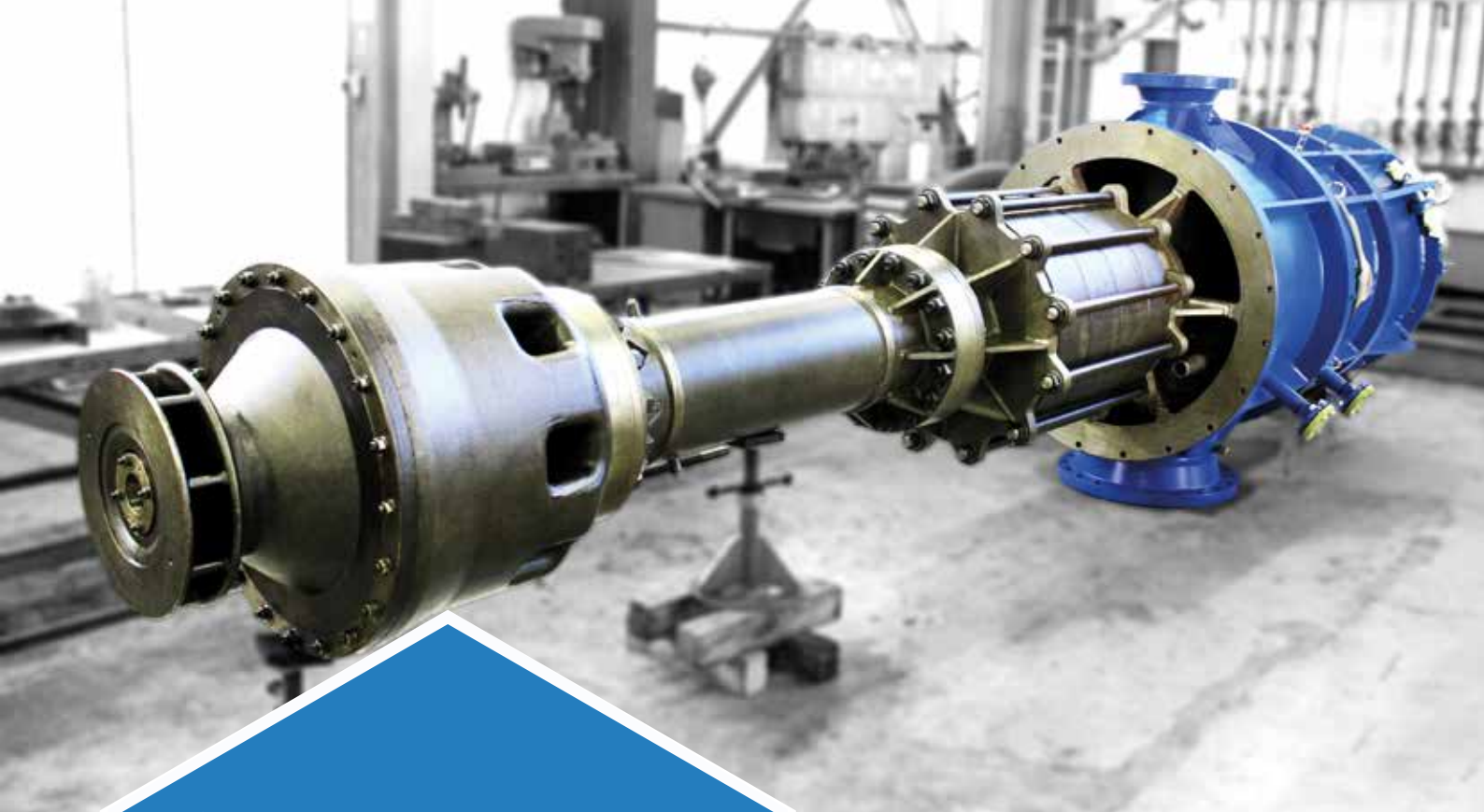

VS6 Pumps

Type GSTV / GLKV / GDTV

Vertical, multistage high-pressure pumps of can-type

Design features

- axial thrust compensation by means of balancing piston
- NPSH impeller as single-flow and double-flow version
- version with diagonal impeller hydraulics for high capacity
- bearing design: antifriction bearings or combined axial-radial slide bearings
- GDTV as single-flow double impeller with inducer optional

	GLKV	GSTV	GDTV
Q (m ³ /h)	400	3 000	3 200
H (m)	250	360	460
P (bar)	40	40/63	40/63
T (°C)	+160	+160	+160

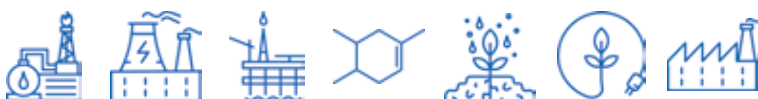



VS6 Pumps

Type HPTV

Vertical, multistage high-pressure pump of can-type

Design features

- pump meets all requirements of API 610
- axial thrust compensation due to balance piston
- NPSH impeller as single-flow or double-flow version
- version with suspended suction impeller possible
- bearing design: antifriction bearing or combined axial-radial slide bearings

HPTV

Q (m ³ /h)	550
H (m)	1 400
P (bar)	40 / 140
T (°C)	-140 / +260

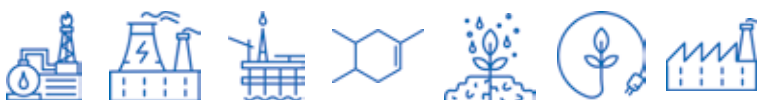

FIRE FIGHTING PUMP acc. to DIN at multi-purpose vessel

- APOLLO pump type: **ZMLKV-300/500-206/GN**
- Vertical, double-flow split-casing centrifugal pump with bearings on both ends
- Liquid: seawater with 8mm solids
- Casing material: brass free of zinc
- Pump power: 446 kW (1400 m³/h of 94 m)





STANDARD PROCESS PUMPS ACCORDING TO ISO

In addition to heavy process technology, Apollo can offer a very large portfolio of standard pumps. This enables us to provide complete solutions for all pump requirements for the customer in the project business.

The Apollo standard pumps are designed according to ISO 5199, ISO 22858 or other relevant standardizations. All Apollo standard pumps can be tailored to worldwide industrial or chemical process applications.

For difficult fluids such as corrosives and toxic liquids Apollo provide magnetic coupled solutions.

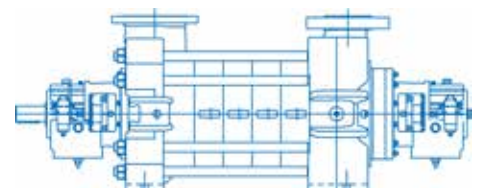
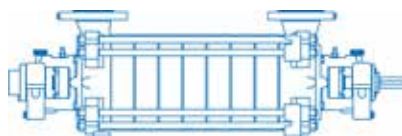
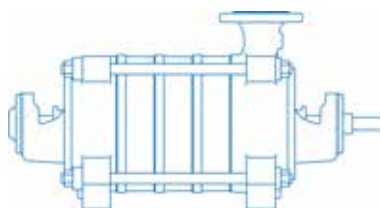

Multistage horizontal
high-pressure pumps
16 / 25 bar

Q (m ³ /h)	up to 500
H (m)	up to 320
P (bar)	up to 25
T (°C)	up to +140

Multistage horizontal
high-pressure pumps
63 bar

Q (m ³ /h)	up to 550
H (m)	up to 550
P (bar)	up to 63
T (°C)	up to +200

Multistage horizontal
high-pressure pumps
100 bar

Q (m ³ /h)	up to 720
H (m)	up to 900
P (bar)	up to 100
T (°C)	up to +180

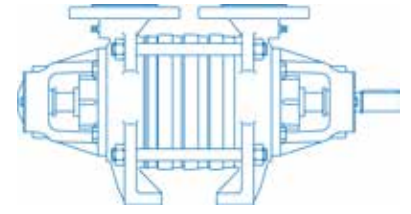
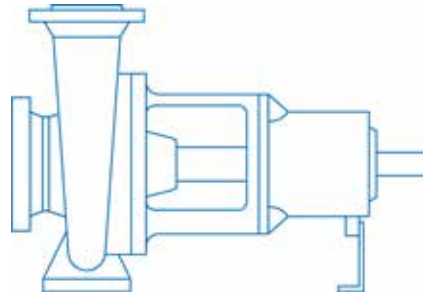
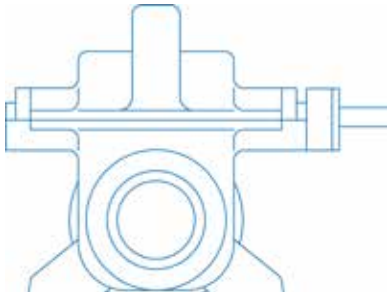

Centrifugal double-flow split-casing pumps with bearings on both ends

Single-stage centrifugal pumps

Self-priming side channel pumps

Q (m ³ /h)	up to 10 000
H (m)	up to 200
P (bar)	up to 25
T (°C)	up to +150

Q (m ³ /h)	up to 3 000
H (m)	up to 160
P (bar)	up to 16 / 25
T (°C)	up to +180

Q (m ³ /h)	up to 35
H (m)	up to 340
P (bar)	up to 40
T (°C)	up to +250

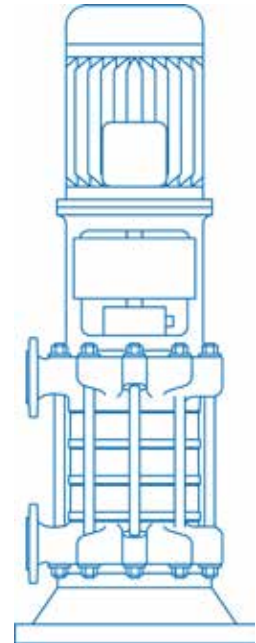
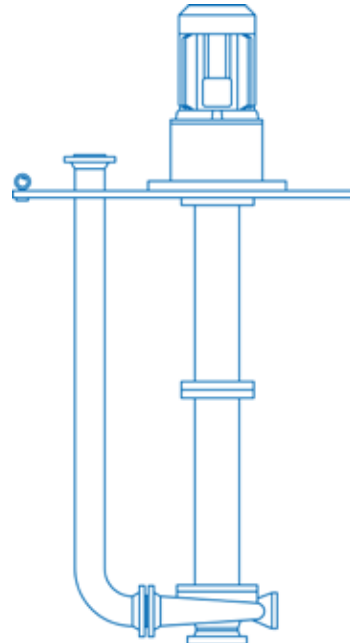
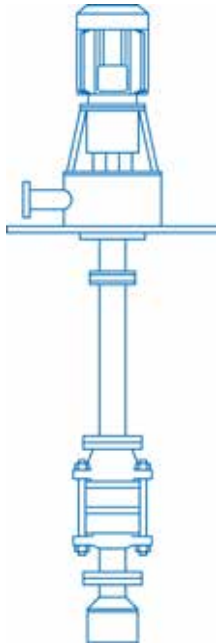

Multistage vertical high-pressure pumps

Single-stage vertical centrifugal pumps

Multistage vertical dry mounted pumps

Q (m ³ /h)	up to 600
H (m)	up to 550
P (bar)	up to 64
T (°C)	up to +180

Q (m ³ /h)	up to 35
H (m)	up to 340
P (bar)	up to 40
T (°C)	up to +250

Q (m ³ /h)	up to 500
H (m)	up to 220
P (bar)	up to 25
T (°C)	up to +140

PUMPING STATIONS AND SYSTEMS

SYSTEM ENGINEERING DIVISION

ENGINEERING

Apollo offers a comprehensive range of design and planning capabilities for a diverse array of pumping systems and packages. Our services encompass both, basic and detail engineering, CAD-supported design, piping, and steel construction, as well as mechanical and electrical engineering of plants and components. Apollo provides high quality, an innovative spirit, expertise in all necessary disciplines, and the most advanced technical equipment for your industrial application.

PIPING / STEEL STRUCTURE

Apollo manufactures a range of products, including tanks, piping, steel framework, and equipment, in accordance with applicable regulations and standards. The same standards are applied to the installation of components and piping systems, which are manufactured, tested, and assembled according to various norms and regulations.

WELDING

In particular, Apollo is certified as a welding specialist company according to DIN EN ISO 3834-2 and DIN EN 1090, in recognition of the complex requirements in the field of welding technology. Apollo is able to weld in accordance with European norms as well as with ASME B31.1 and ASME IX. The assurance of all welding technical tasks is carried out by a team of welding engineers and a team of welding specialists, who are able to implement the most diverse welding processes. The company offers its services in the following areas: titanium, super duplex, duplex, stainless steel, and carbon steel.

«Everything from one
source under one roof»

In 1990, the system engineering department was established, with the core competencies of pipe technology, welding technology, skid systems, package units, assembly, and service. Apollo system engineering adheres to high welding standards and is also knowledgeable regarding the functionality of fluid components in complete systems. The pumping and system equipment is manufactured according to PED 2014/68/EU, AD2000, and ASME, among others.





MANUFACTURING OF SKIDS AND SYSTEMS

Apollo develops and supplies customized fluid systems for a diverse range of customer applications. The company's manufacturing process for engineered systems in conjunction with process pumps is based on a foundation of extensive experience and highly trained personnel.

AUTOMATION / ELECTRICAL ENGINEERING

Apollo offers a range of automation solutions and diagnostic techniques that can be tailored to the specific requirements of each customer application.

The EI&C services include all essential processes and work steps, from project planning and detailed design to the required installation and electrical wiring, operation and project documentation. Standard machine monitoring, machine protection, machine diagnostic and individual programming can also be provided.



UNITS FOR LIQUID FUELS

- Supply Systems for Gas Turbines
- Forwarding pump skids
- Flow and pressure regulating systems
- Filtering systems
- Preheating / Cooling Systems
- Flow measuring systems
- Loading and unloading stations for Railway, Trucks and Marine



CUSTOM-MADE SYSTEMS

- Injector pump systems
- Clean condensate systems
- Cooling water system
- Brine pumping systems
- Sprinkling systems
- NOx pump skids
- Dozing pump systems
- Thermosiphon systems
- Refrigerant plants
- Condensate systems



UNITS FOR WATER INDUSTRY

- Booster stations
- Pump stations of ready-made concrete elements
- Container pump stations
- Water plant equipment
- Fire-fighting systems
- Irrigation systems



LUBE OIL UNITS

- According to API 614 or manufacturer standard
- Use for oil supply of pumps, gear-boxes, turbines, motors, bearings or other similar applications

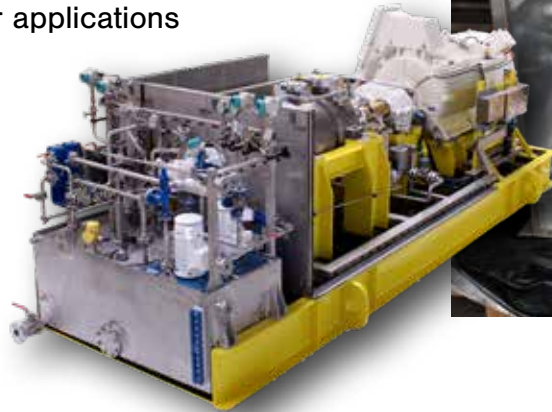

AUTOMATION | ELECTRICAL ENGINEERING

- Junction boxes, local control panels & cabinets
- Low-voltage switchboard systems
- Pump / Motor Control Systems
- Control and regulation of complete systems
- Machine monitoring systems



We are **Experts**

Apollo is a reliable skid manufacturer and supplier for leading EPC companies.

Whether in the water and wastewater industry, process industry, chemical and petrochemical industry or the field of power generation. Apollo develops and manufactures complex systems in various sizes, material combinations and according customer requirements.





COMMISSIONING / COMPLETE ASSEMBLY ON SITE



24/7 SITE SERVICE / TECHNICAL SUPPORT



MAINTENANCE



UPGRADE / RETROFIT



EDUCATION & TRAINING



SPARE PARTS

COMPREHENSIVE SERVICE WORLDWIDE

We offer our customers a comprehensive range of service and the best possible support during the operation of our pumps and pumping systems. We guarantee quick service worldwide. Our experienced service team is available 24/7 to ensure that you always have the assistance you need.



«CUSTOMER SATISFACTION - OUR PRIORITY»

At Apollo, we prioritize the quality of our products and services. This commitment extends from the sale of our high-quality pumping systems to the after-sales service we provide. Reliability and customer satisfaction are our primary objectives.

In addition to offering a comprehensive range of high-quality pumps for a wide variety of systems, we also provide exemplary customer support. Our training courses and comprehensive documentation are designed to provide operators with the knowledge and resources necessary to operate and maintain our equipment effectively.

A comprehensive range of spare parts is available for the entire operational life cycle of the pump and pumping system. In the event of an emergency, a fast track supply of spare parts can be provided.





Apollo Gößnitz GmbH
Walter-Rabold-Strasse 26
04639 Gößnitz / Germany
Phone: +49 34493 - 77 0
Fax: +49 34493 - 77 210
E-Mail: sales@apollo-goessnitz.de

www.apollo-goessnitz.de

[f](#) [@](#) [in](#)

The information contained in this brochure is intended for reference purposes only and basic selection of products manufactured by Apollo. Full and detailed technical information regarding specific products is available in requested at Apollo. Apollo reserves the right to alter the products without prior notice and is not responsible for possible errors and misprints in catalogs, brochures and other printed or published materials in any form.